



U.S. Department  
of Transportation  
**Federal Highway  
Administration**

1200 New Jersey Ave., SE  
Washington, D.C. 20590

May 24, 2012

In Reply Refer To:  
WZ-317

Kenneth Parrott  
Impact Recovery Systems, Inc.  
4955 Stout Dr.  
San Antonio, Texas 78219

Dear Mr. Parrott:

This letter is in response to your request for the Federal Highway Administration (FHWA) to review a roadside safety system for eligibility for reimbursement under the Federal-aid highway program.

Name of system:	Tuff Curb© XLP
Type of system:	Channelizing curb system
Test Level:	MASH Test Level 3
Testing conducted by:	Texas Transportation Institute
Date of request:	July 15, 2011

**Decision:**

The following device is eligible, with details provided below and in the form which is attached as an integral part of this letter:

- Tuff Curb XLP channelizing curb system.

Based on a review of crash test results submitted by the manufacturer certifying the device described herein meets the crash test and evaluation criteria of the American Association of State Highway and Transportation Officials' Manual for Assessing Safety Hardware (MASH), the device is eligible for reimbursement under the Federal-aid highway program. Eligibility for reimbursement under the Federal-aid highway program does not establish approval or endorsement by the FHWA for any particular purpose or use.

The FHWA, the Department of Transportation, and the United States Government do not endorse products or services and the issuance of a reimbursement eligibility letter is not an endorsement of any product or service.

**Requirements**

To be found eligible for Federal-aid funding, roadside safety devices should meet the crash test and evaluation criteria contained in the American Association of State Highway and Transportation Officials' Manual for Assessing Safety Hardware (MASH).

### **Description**

Tuff Curb® XLP is a longitudinal channelizing curb system produced by Impact Recovery Systems, Inc. Tuff Curb® XLP consists of two pieces. One is a single piece curb section measuring 40 inches long x 8 inches wide x 2 inches high made of High Density Polyethylene and weighing approximately seven pounds. It is attached to the roadway by way of lag bolts through two or three anchor holes within the curb or with highway grade adhesives. The second piece is an optional coupler which bridges between curb sections, measuring 10 inches long x 8 inches wide x 1.75 inches high also made of High Density Polyethylene and weighing approximately 2 pounds. It is attached to the roadway by way of two holes which are co-aligned with adjoining curb sections and anchors by way of the same lag bolt, or through adhesives. It should be noted that all tests were conducted with vertical road tubes in place.

Subsequent to MASH testing of the curb system on January 19, 2011 at Texas Transportation Institute, twenty two (22) additional tests were performed on January 27, 2011, also at Texas Transportation institute using two anchor configurations, three anchor configurations, and epoxy and Super Bundy adhesives:

1. Traversal of Curb at 25° - Pass – Vehicle stable and no compartment penetration or deformation
2. Traversal of Curb at 0° - Pass – Vehicle stable and no compartment penetration or deformation

### **Summary and Standard Provisions**

Therefore, the system described above and detailed in the attached form is eligible for reimbursement and may be installed under the range of conditions tested. Please note the following standard provisions that apply to FHWA eligibility letters:

- This finding of eligibility does not cover other structural features of the systems, nor conformity with the Manual on Uniform Traffic Control Devices.
- Any changes that may influence system conformance with MASH will require a new reimbursement eligibility letter.
- Should the FHWA discover that the qualification testing was flawed, that in-service performance reveals safety problems, or that the system is significantly different from the version that was crash tested, we reserve the right to modify or revoke this letter.
- You are expected to supply potential users with sufficient information on design and installation requirements to ensure proper performance.
- You are expected to certify to potential users that the hardware furnished has the same chemistry, mechanical properties, and geometry as that submitted for review, and that it will meet the test and evaluation criteria of the MASH.
- To prevent misunderstanding by others, this letter of eligibility is designated as number WZ-317 and shall not be reproduced except in full. This letter and the test documentation upon which it is based are public information. All such letters and documentation may be reviewed at our office upon request.

- This letter shall not be construed as authorization or consent by the FHWA to use, manufacture, or sell any patented system for which the applicant is not the patent holder. The FHWA does not become involved in issues concerning patent law. Patent issues, if any, are to be resolved by the applicant.
- The Tuff Curb® XLP is a patented product and considered proprietary. If proprietary systems are specified by a highway agency for use on Federal-aid projects: (a) they must be supplied through competitive bidding with equally suitable unpatented items; (b) the highway agency must certify that they are essential for synchronization with the existing highway facilities or that no equally suitable alternative exists; or (c) they must be used for research or for a distinctive type of construction on relatively short sections of road for experimental purposes. Our regulations concerning proprietary products are contained in Title 23, Code of Federal Regulations, Section 635.411.

Sincerely yours,

A handwritten signature in blue ink that reads "Michael S. Griffith". The signature is written in a cursive style with a large, stylized initial "M".

Michael S. Griffith  
Director, Office of Safety Technologies  
Office of Safety

Enclosures

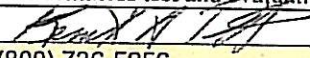
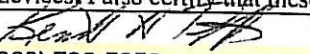
Page 1	<b>FEDERAL HIGHWAY ADMINISTRATION OFFICE OF SAFETY DESIGN</b>		Letter Number
	<b>Category 2 Work Zone Device Acceptance Letter</b>		Date
			07/15/2011
Contact Info	Petitioner / Developer Name and Address:		
	Impact Recovery Systems, Inc. c/o Kenneth Parrott 4955 Stout Drive San Antonio, TX 78219		
	I hereby certify that the device(s) covered by this Acceptance Letter meet(s) the crash - worthiness test and evaluation requirements of the FHWA and NCHRP Report 350.		
Signature			
Telephone #	(800) 736-5256		
Email Address	kparrott@impactrecovery.com		
	Laboratory / Engineer Name and Address		
	Texas Transportation Institute, Texas A&M University 3135 TAMU College Station, TX 77843-3135		
<input checked="" type="checkbox"/>	I hereby certify that the testing that supports this Acceptance Letter was conducted in accordance with NCHRP Report 350 guidelines, that the device(s) tested is/are accurately described on this form, and that the test results indicate that the device meets all applicable NCHRP Report 350 evaluation criteria.		
<input type="checkbox"/>	I have evaluated the requested modifications to these devices previously found acceptable by the FHWA in Acceptance Letter WZ-___, and hereby certify that, in my opinion, the modifications do not adversely affect the crash performance of the devices. I also certify that these devices are accurately described on this form.		
Signature			
Telephone #	(800) 736-5256		
Email Address	kparrott@impactrecovery.com		
Keywords:			
	Type of Device (See page 3) Longitudinal Channelizing Barricade Curb (Curb channelizer system with or without road Composition of Sign or Rail substrate (See Page 3)		
	Thickness of substrate (inches):		
	Height of sign from the ground (inches), if applicable: (See Page 3)		
	Flags and or lights present during test? Indicate number of each:		
	# of flags:	# of lights:	Weight of lights: ea.
Device Name	Tuff Curb XLP		
Detailed Desc. Of Device, Materials, sizes, Fasteners, Substrates Foundation, Aux. Features Ballast, etc.	(May be attached on separate page(s) Tuff Curb® XLP is a longitudinal channelizing curb system consisting of two pieces. One is a single piece curb section measuring 40"L x 8"W x 2"H made of HDPE and weighing approximately seven (7) pounds. It is attached to the roadway by way of lag bolts through two (2) or three (3) anchor holes within the curb or with highway grade adhesives. The second piece is an optional coupler which bridges between curb sections, measuring 10"L x 8"W x 1.75"H also made of HDPE, attach by the same method.		

Page 2	<b>FEDERAL HIGHWAY ADMINISTRATION OFFICE OF SAFETY DESIGN Category 2 Work Zone Device Acceptance Letter</b>		Letter Number
			Date
			07/15/2011
	<b>Mandatory Attachments</b>		
	<b>Attachment # 1:</b> Test data summary page(s)		
	Attach. #1a	Test # IRS6 9-16	
	Attach. #1b	Test # IRS7 XLP 1-5	
	Attach. #1c	Test # IRS7 XLP 1-17	
	Attach. #1d	Test #	
Alternative	<b>Attachment # 1:</b> Description and discussion of modification(s) to crash tested and/or accepted device.		
	Date:		
	<b>Attachment # 2:</b> PDF drawing(s) of device(s)		
	Attach. #2a	Drawing Title: Tuff Curb XLP	
		Drawing #:	
	Attach. #2b	Drawing Title: Tuff Curb XLP Coupler	
		Drawing #:	
	Attach. #2c	Drawing Title:	
		Drawing #:	
	Attach. #2d	Drawing Title:	
		Drawing #:	
	Attach. #2e	Drawing Title:	
		Drawing #:	
	Attach. #2f	Drawing Title:	
		Drawing #:	
	Attach. #2g	Drawing Title:	
		Drawing #:	

Page 3	FEDERAL HIGHWAY ADMINISTRATION OFFICE OF SAFETY DESIGN Category 2 Work Zone Device Acceptance Letter	Letter Number
		Date
		07/15/2011

**Please select from the following Keywords for “Type of Device”:**

Longitudinal Channelizing Barricade  
 Curb (Curb channelizer system with or without road tubes or other channelizers)  
 Drum  
 H-Footprint Sign Stand  
 X-Footprint Sign Stand  
 Trailer Mounted Signs (Does not include arrow boards or variable message signs or other Category 4 trailer mounted devices.)  
 Automated Flagger Device (not trailer mounted)  
 Tripod Sign Stand  
 Type I Barricade  
 Type II Barricade  
 Type III Barricade  
 Vertical Panel  
 Intrusion Detector  
 Ballast (Action relates to ballast on one or more devices)  
 Channelizer (Individual units unlike cones, road tubes, or drums)

**Please select from the following Keywords for “Sign Substrate”:**

Roll-up / Fabric (with fiberglass spreaders – aluminum or steel spreaders are not allowed.)  
 Plywood  
 Aluminum – Solid  
 Aluminum – Laminate  
 Corrugated Plastic  
 Extruded Plastic  
 Waffleboard Plastic  
 Wood / Lumber

**Please select from the following Keywords for “Height of Sign”:**

The distance to the lowest point on the sign is:

Low            12 to 18 inches above the pavement  
 Mid-A         20 to 24 inches above the pavement  
 Mid-B         25 to 36 inches above the pavement  
 Mid-C         37 to 59 inches above the pavement  
 Tall            60 to 71 inches above the pavement  
 Oversized     72 inches and taller

Page 4	FEDERAL HIGHWAY ADMINISTRATION OFFICE OF SAFETY DESIGN Category 2 Work Zone Device Acceptance Letter		Letter Number
			Date

Please note the following standard provisions that apply to FHWA letters of acceptance:

- Our acceptance is limited to the crashworthiness characteristics of the devices and does not cover their structural features, or conformity with the Manual on Uniform Traffic Control Devices.
- Any changes that may adversely influence the crashworthiness of the device will require a new acceptance letter.
- Should the FHWA discover that the qualification testing was flawed, that in-service performance reveals unacceptable safety problems, or that the device being marketed is significantly different from the version that was crash tested, it reserves the right to modify or revoke its acceptance.
- You will be expected to supply potential users with sufficient information on design and installation requirements to ensure proper performance.
- You will be expected to certify to potential users that the hardware furnished has essentially the same chemistry, mechanical properties, and geometry as that submitted for acceptance, and that they will meet the crashworthiness requirements of FHWA and NCHRP Report 350.
- To prevent misunderstanding by others, this letter of acceptance shall not be reproduced except in full. This letter, and the test documentation upon which this letter is based, is public information. All such letters and documentation may be reviewed at our office upon request.
- If the subject of this letter is a patented device it is considered "proprietary." The use of proprietary work zone traffic control devices in Federal-aid projects is generally of a temporary nature. They are *selected by the contractor* for use as needed and removed upon completion of the project. Under such conditions they can be presumed to meet requirement "a" given below for the use of proprietary products on Federal-aid projects. On the other hand, if proprietary devices are *specified by a highway agency* for use on Federal-aid projects they: (a) must be supplied through competitive bidding with equally suitable unpatented items; (b) the highway agency must certify that they are essential for synchronization with existing highway facilities or that no equally suitable alternative exists or; (c) they must be used for research or for a distinctive type of construction on relatively short sections of road for experimental purposes. Our regulations concerning proprietary products are contained in Title 23, Code of Federal Regulations, Section 635.411, a copy of which is enclosed.
- This Acceptance Letter shall not be construed as authorization or consent by the Federal Highway Administration to use, manufacture, or sell any patented device for which the applicant is not the patent holder. The Acceptance Letter is limited to the crashworthiness characteristics of the candidate device, and the FHWA is neither prepared nor required to become involved in issues concerning patent law. Patent issues, if any, are to be resolved by the applicant.

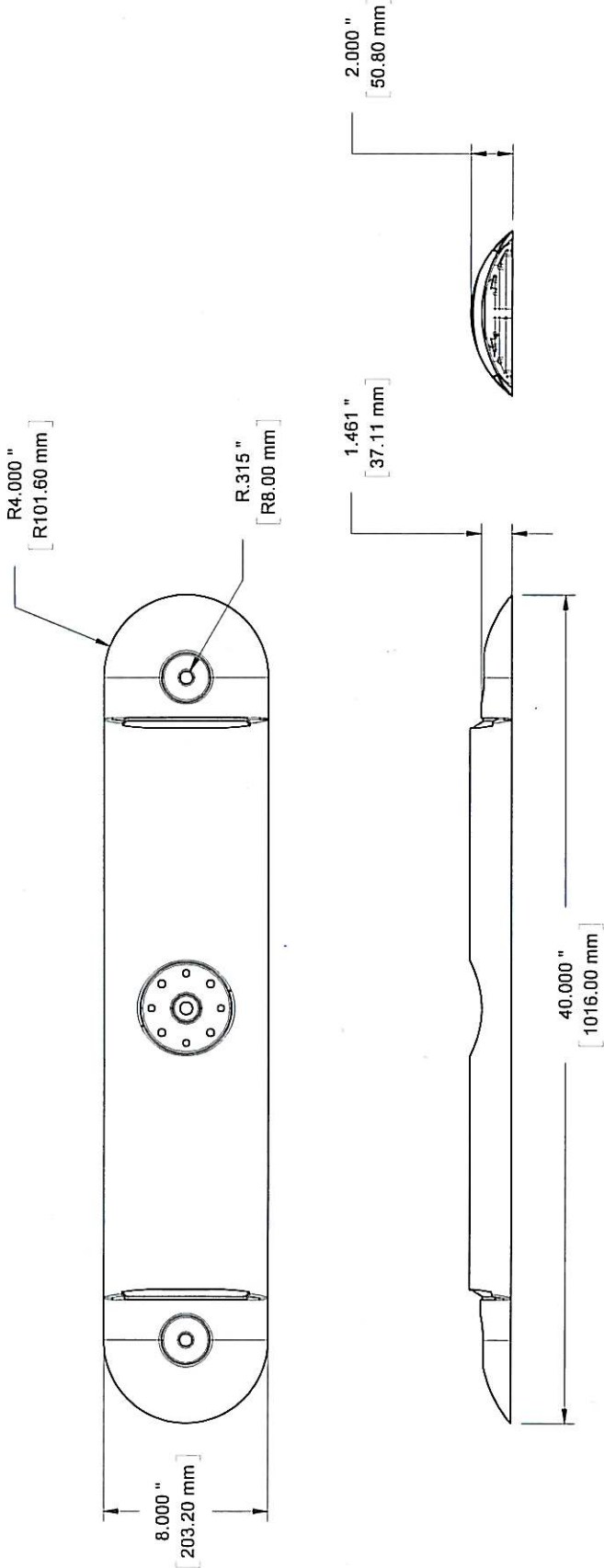

**MANUFACTURING INFORMATION**

- 1. INJECTION MOLDED
- 2. UV STABILIZED HDPE
- 3. COLORS: WHITE, YELLOW, CUSTOM

**INTENDED USE**

- 1. FOR USE AS A TEMPORARY OR PERMANENT LONGITUDINAL CHANNELIZING CURBING SYSTEM ON ROADS, HIGHWAYS, AND PARKING LOTS.
- 2. CRASHWORTHINESS TESTED TO 2009 M.A.S.H. STANDARDS.
- 3. INSTALL USING 1/2"-5/8" CONCRETE LAG ANCHORS OR STANDARD ROAD EPOXY PRODUCTS

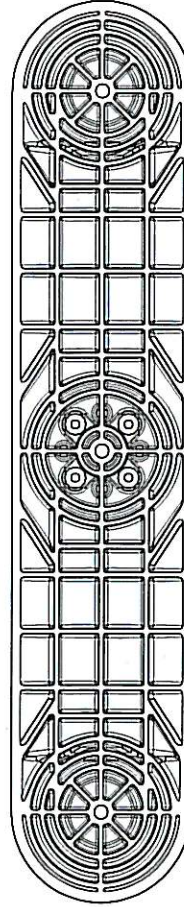

**IMPACTrecovery**  
**SYSTEMS**

"Performance for a Safer Tomorrow"

4955 STOUT DR. · SAN ANTONIO, TX 78219 · (800) 736-5256

SIZE	PART NO.	DWG.	REV
A		TUFF CURB® XLP	
SCALE	1:8	IMPACT RECOVERY SYSTEMS, INC.	DATE 02-10-11



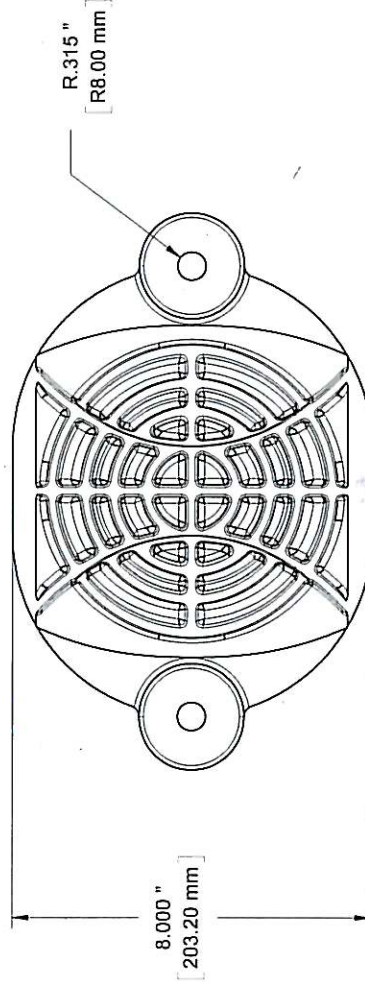
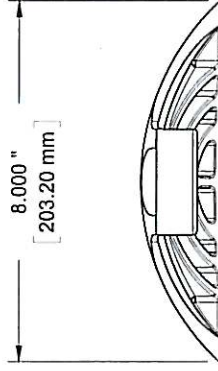
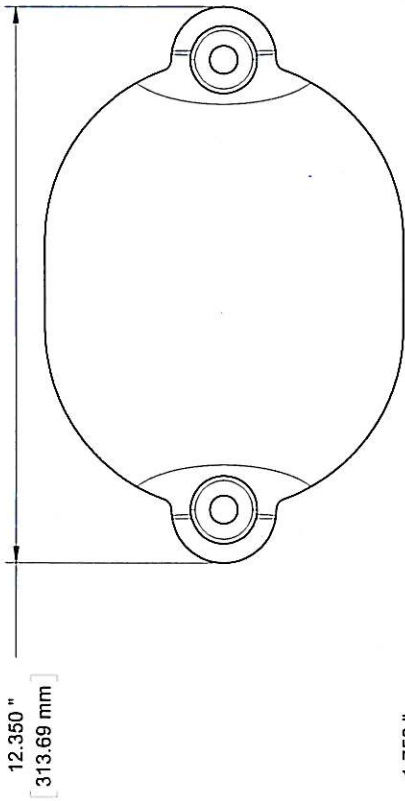

**MANUFACTURING INFORMATION**

1. INJECTION MOLDED
2. UV STABILIZED HDPE
3. COLORS: WHITE, YELLOW, CUSTOM

**INTENDED USE**

1. FOR USE AS A TEMPORARY OR PERMANENT LONGITUDINAL CHANNELIZING CURBING SYSTEM ON ROADS, HIGHWAYS, AND PARKING LOTS.
2. CRASHWORTHINESS TESTED TO 2009 M.A.S.H. STANDARDS.
3. INSTALL USING 1/2"-5/8" CONCRETE LAG ANCHORS OR STANDARD ROAD EPOXY PRODUCTS

**IMPACTrecovery**  
**S Y S T E M S**

"Performance for a Safer Tomorrow"

4955 STOUT DR. · SAN ANTONIO, TX 78219 · (800) 736-5256

SIZE	PART NO.	DWG.	REV
A		TUFF CURB® XLP COUPLER	
SCALE	1:4	IMPACT RECOVERY SYSTEMS, INC.	DATE 02-10-11